

Swing Check VALVE

Features

- Prevents fluid backflow and protects pump facilities.
- Arm-type check valve prevents fluid resistance increase.
- All-plastic material provides high resistance to corrosive fluid including ACID and ALKALI.
- Internal maintenance only requires removal of bonnet.



Basic specifications

- Valve Type : Swing Check Valve
- Size : 15 mm — 200 mm (1/2 inch — 8 inch)
- Body Material :
 - HI-PVC (Conforming to ASTM D1784)
 - PP (Conforming to ASTM D4101 Cell Classification PP0210B67272)
 - PVDF / EL-PVDF (Conforming to ASTM D3222 Cell Classification Type II)
- Seal Material / O-ring : EPDM, FKM, PTFE, Viton-F, Viton-C
- Connection / Flanged : JIS B2220 5K, JIS B2220 10K, DIN/EN1092-1 PN10, ANSI B16.5 CLASS150

Body Material	FLUID TEMPERATURE °C { F }	Maximum working pressure (Normal temperature) MPa { psi }		
		15mm-80mm	100mm-150mm	200mm
HI-PVC	0 ~ 50 { 30~120 }	1.0 { 150 }	0.7 { 100 }	0.5 { 70 }
PP	-20 ~ 80 { -5~175 }	1.0 { 150 }	0.7 { 100 }	0.5 { 70 }
PVDF/ELPVDF	-20 ~ 100 { -5~210 }	1.0 { 150 }	0.7 { 100 }	0.5 { 70 }

Note: The maximum working pressure is the value including the water hammer pressure. Be careful that the maximum working pressure is not exceeded during use.

*Concerning the allowable pressure for each temperature and material, see the technical documents at the next page of this sheet.

Certificate / Approval / Directive

PED

“For details of applicable products, please consult us.”

Working pressure vs. Temperature

[SWING CHECK VALVE (O-RING TYPE)]

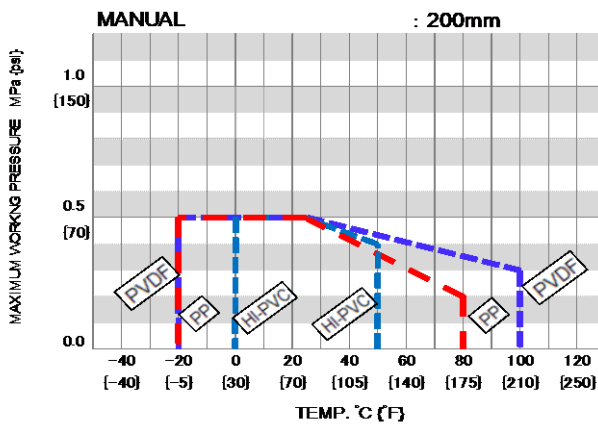
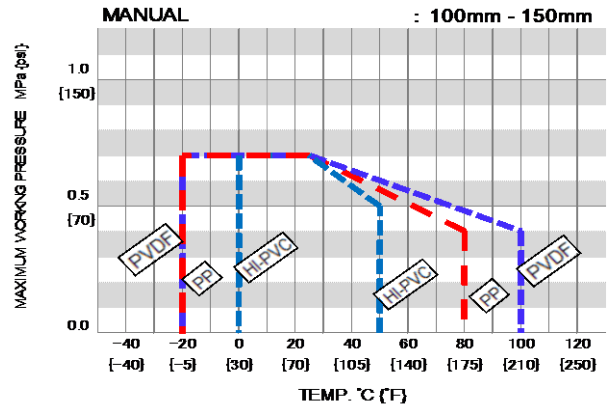
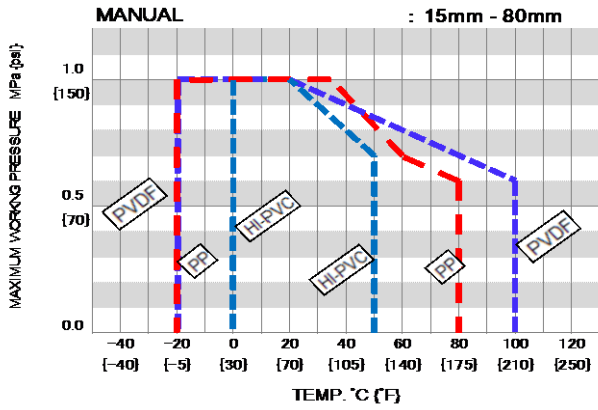

Make sure that the temperature and pressure are within the working range during operation.
 (If the tolerance range is exceeded during use, the valve may be damaged.)

Product dimension

15mm (1/2") - 20mm (3/4")

25mm (1") - 200mm (8")

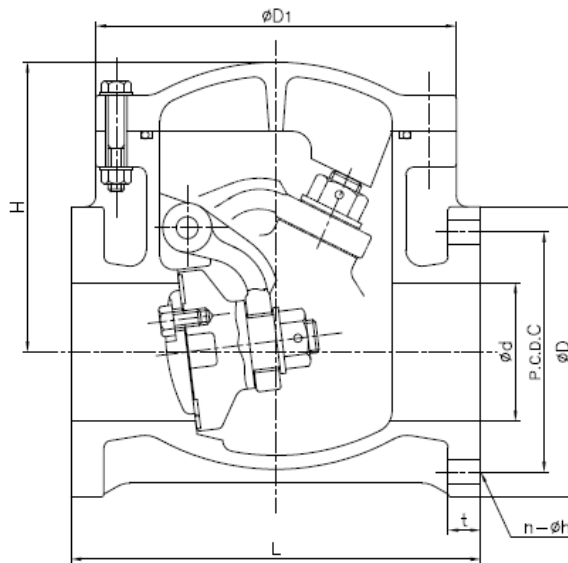
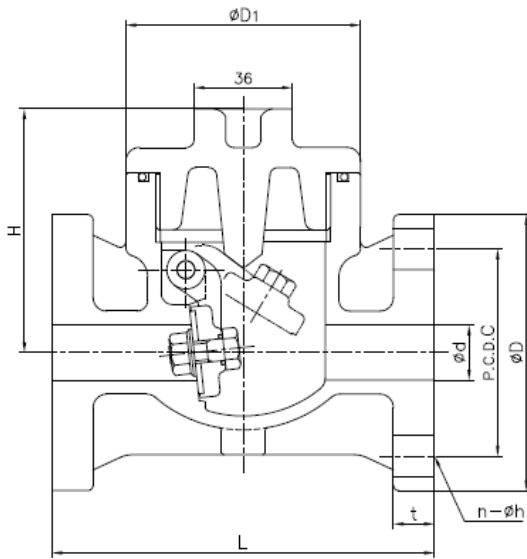

■ JIS, DIN (Unit: mm)

mm	inch	d	D ₁	H	L	t			JIS 5K				JIS 10K				DIN PN10			
						HI-PVC	PVDF	PP	D	C	n	h	D	C	n	h	D	C	n	h
15	1/2	20	86	87	140	15	15	15	80	60	4	12	95	70	4	15	95	65	4	14
20	3/4	20	86	87	140	15	15	15	85	65	4	12	100	75	4	15	105	75	4	14
25	1	25	130	117	160	16	16	16	95	75	4	12	125	90	4	19	115	85	4	14
32	1 1/4	40	145	135	180	18	18	17	-	-	-	-	135	100	4	19	140	100	4	18
40	1 1/2	40	145	135	180	18	18	17	120	95	4	15	140	105	4	19	150	110	4	18
50	2	50	180	161	200	20	20	20	130	105	4	15	155	120	4	19	165	125	4	18
65	2 1/2	65	200	165	240	22	23	22	155	130	4	15	175	140	4	19	185	145	4	18
80	3	80	205	168	260	22	23	22	180	145	4	19	185	150	8	19	200	160	8	18
100	4	100	265	210	300	24	26	24	200	165	8	19	210	175	8	19	220	180	8	18
125	5	125	330	245	350	24	26	25	235	200	8	19	250	210	8	23	250	210	8	18
150	6	150	370	280	400	25	27	26	265	230	8	19	280	240	8	23	285	240	8	22
200	8	200	425	333	500	30	33	31	320	280	8	23	330	290	12	23	340	295	8	22

■ ANSI (Unit: inch)

inch	mm	d	D ₁	H	L	t			ANSI Class150			
						HI-PVC	PVDF	PP	D	C	n	h
1/2	15	0.79	3.39	3.43	5.51	0.59	0.59	0.59	3.50	2.38	4	0.62
3/4	20	0.79	3.39	3.43	5.51	0.59	0.59	0.59	3.88	2.75	4	0.62
1	25	0.98	5.12	4.61	6.30	0.63	0.63	0.63	4.25	3.12	4	0.62
1 1/4	32	-	-	-	-	-	-	-	-	-	-	-
1 1/2	40	1.57	5.71	5.31	7.09	0.71	0.71	0.67	5.00	3.88	4	0.62
2	50	1.97	7.09	6.34	7.87	0.79	0.83	0.79	6.00	4.75	4	0.75
2 1/2	65	2.56	7.87	6.50	9.45	0.87	0.91	0.87	7.00	5.50	4	0.75
3	80	3.15	8.07	6.61	10.24	0.87	0.91	0.87	7.50	6.00	4	0.75
4	100	3.94	10.43	8.27	11.81	0.94	1.02	0.94	9.00	7.50	8	0.75
5	125	4.92	12.99	9.65	13.78	0.94	1.02	0.98	10.00	8.50	8	0.88
6	150	5.91	14.57	11.02	15.75	0.98	1.06	1.02	11.00	9.50	8	0.88
8	200	7.87	16.73	13.11	19.69	1.18	1.30	1.22	13.50	11.75	8	0.88

Parts list

[HI-PVC, PVDF]

15mm (1/2") - 20mm (3/4")

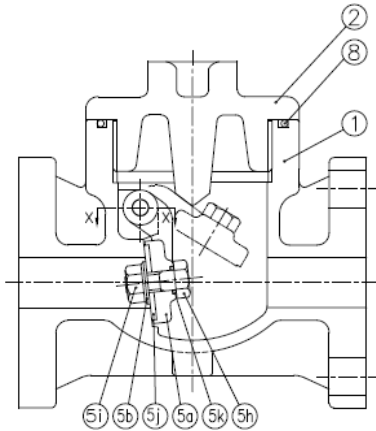

25mm (1") - 200mm (8")

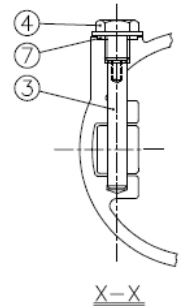
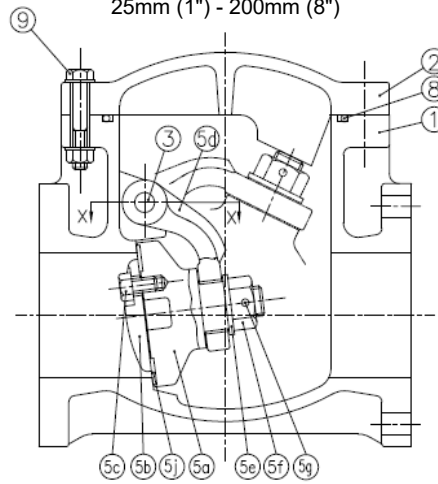

PART NO./NAME	QTY	MATERIAL	PART NO./NAME	QTY	MATERIAL	PART NO./NAME	QTY	MATERIAL
1 BODY	1	HI-PVC, PVDF/EL-PVDF	5d ARM ⁽³⁾	1	HI-PVC, PVDF/EL-PVDF	5j SEAT ⁽¹⁾	1	EPDM / EPDM FKM / FKM
2 BONNET	1	HI-PVC, PVDF/EL-PVDF	5e WASHER ⁽³⁾	1	HI-PVC, PVDF	5k O-RING (A) ⁽¹⁾	1	PTFE / PFA ⁽²⁾
3 SHAFT	1	HI-PVC, PVDF	5f NUT (A) ⁽³⁾	1	HI-PVC, PVDF	7 GASKET (B)	1	GASKET / O-RING (B)
4 PLUG	1	HI-PVC, PVDF	5g PIN	1	HI-PVC, PVDF	8 O-RING (B)	1	GASKET O-RING(A) / O-RING (B)
5a DISC	1	HI-PVC, PVDF/EL-PVDF			In Case Material is PVDF, Used for Size 65mm-200mm	9 BOLT·NUT	-	STAINLESS STEEL Used for Size 25mm-200mm
5b SEAT HOLDER	1	HI-PVC, PVDF/EL-PVDF	5h BOLT (B) ⁽¹⁾	1	PP Used for Size 15mm & 25mm			
5c BOLT (A) ⁽³⁾	-	HI-PVC, PVDF	5i NUT (B) ⁽¹⁾	1	PP Used for Size 15mm & 25mm			

(1) Used for Size 15mm & 20mm. (2) FKM Covered at PFA. (3) Used for Size 25mm - 200mm

[PP]

15mm (1/2") - 20mm (3/4")

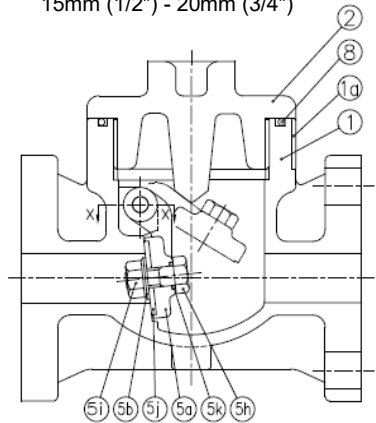

25mm (1") - 200mm (8")

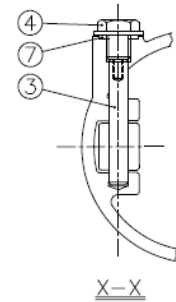
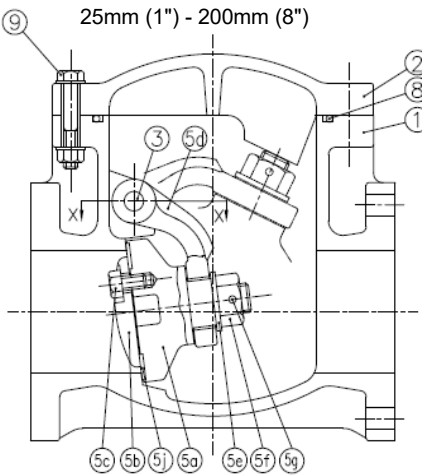

PART NO./NAME	QTY	MATERIAL	PART NO./NAME	QTY	MATERIAL	PART NO./NAME	QTY	MATERIAL
1 BODY	1	PP	5e WASHER	1	PP Used for Size 25mm-200mm	5j SEAT	1	EPDM / EPDM FKM / FKM
2 BONNET	1	PP	5f NUT (A)	1	PVDF Used for Size 25mm-200mm	5k O-RING (A) ⁽¹⁾	1	EPDM / EPDM FKM / FKM
3 SHAFT	1	PP	5g PIN	1	PVDF Used for Size 65mm-200mm	7 GASKET (B)	1	GASKET / O-RING (B)
4 PLUG	1	PP	5h BOLT (B)	1	PP Used for Size 15mm & 25mm	8 O-RING (B)	1	GASKET O-RING(A) / O-RING (B)
5a DISC	1	PVDF	5i NUT (B)	1	PP Used for Size 15mm & 25mm	1a BODY RING	1	STAINLESS STEEL In Case Material is PP, Used for Size 15mm&20mm
5b SEAT HOLDER	1	PP	9 BOLT·NUT	-	STAINLESS STEEL Used for Size 25mm-200mm			
5c BOLT (A)	-	PP Used for Size 25mm-200mm						
5d ARM	1	PP Used for Size 25mm-200mm						

(1) Used for Size 15mm & 20mm.

Cv value for each opening degree

FULL-OPEN Cv VALUE

mm	15	20	25	40	50	65	80	100	125	150	200
inch	1/2	3/4	1	1 1/2	2	2 1/2	3	4	5	6	8
FULL-OPEN Cv VALUE	14	14	24	81	140	250	280	510	750	1100	1900

The values shown are reference values, not guaranteed values.

Pipe bolt dimensions (Reference: recommended data)

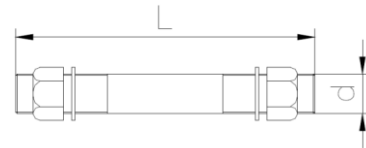

SWING CHECK VALVE

FLANGED (JIS10K)

UNIT: mm

SIZE	15	20	25	32	40	50	65	75(80)	100	125	150	200
SCREW SIZE (d)	M12	M12	M12	M16	M16	M16	M16	M16	M16	M20	M20	M20
NO.OF FLANGE HOLES	4	4	4	4	4	4	4	8	8	8	8	12
FLANGE THICKNESS	14	15	15	16	16	20	22	22	22	24	26	28
SWING CHECK VALVE (L)	55	55	60	60	65	70	75	75	75	85	85	100

The above values indicate the bolt dimensions when an AV TS flange and AV packing are used.

The numbers in a circle indicate the number of bolts required to connect one side of flange. When there is no indication, refer to the number of flange holes.

Product weight

SWING CHECK VALVE

UNIT : kg

mm	inch	FLANGED (JIS10K)		
		HI-PVC	PP	PVDF
15	1/2	0.8	0.6	1.0
20	3/4	0.9	0.6	1.0
25	1	1.7	1.2	2.0
32	1 1/4	2.6	1.7	3.0
40	1 1/2	2.6	1.7	3.0
50	2	4.0	2.7	4.6
65	2 1/2	5.5	3.5	6.5
80	3	6.0	4.0	7.5
100	4	10.5	7.0	12.0
125	5	16.0	12.0	20.0
150	6	22.0	16.0	27.0
200	8	34.5	24.5	42.0

Product model code list

ACTUATION	TYPE	OPERATING SYSTEM	BODY MATERIAL	SEAL MATERIAL	CONNECTION	STANDARD	SIZE
V	SC	OR [※]	*	*	F	***	***
V	SC	OR	I	E	F	J	015
MANUAL VALVE	SWING	O-RING	HI-PVC	EPDM	FLANGED	JIS	15mm
			P	V		5	3
			PP	FKM		5K	
			F	P		D	200
			PVDF	PTFE/PFA		DIN	200mm
				3		A	
				PTFE/Viflon-F		ANSI	
				4			
				PTFE/Viflon-C			

※When the seal material is EPDM or FKM, the material of O-ring is the same as that of the seal.

When the seal material is PTFE, the material of O-ring is PFA coating or Viflon.

Note: 15mm type is processed from 20mm, 32mm type is processed from 40mm.

Contact us regarding the combination of body material PP and seal material PTFE/PFA.

Installation, Operation and Maintenance Manual

"For details of Installation, Operation and Maintenance, please contact our nearest distribution agent or sales office.