

BALL VALVE Type 21α

(Flow Control Type)

Features

- Ball valve that enables rough flow rate adjustment.
- With indicator to indicate valve opening degree.
- Please use the indicator as a guide for valve opening.

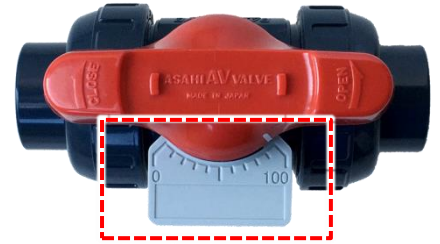

(FULL OPEN)

(MIDDLE OPEN)

(FULL CLOSE)

Basic specifications

- Valve Type : Ball Valve Type 21α (Flow Control Type)
- Size : 15 mm — 50 mm (1/2 inch — 2 inch)
- Body Material : U-PVC (Conforming to ASTM D1784 Cell Classification 12454A)
C-PVC (Conforming to ASTM D1784 Cell Classification 23567-A)
- Seal Material / O-ring : EPDM, FKM etc.
- Connection / Flanged : JIS B2220 10K, DIN/EN1092-1 PN10/PN16, ANSI B16.5 CLASS150
Socket : JIS, DIN, ASTM D2466 SCH80
Threaded : Rc, Rp, NPT
Spigot : DIN

Body Material	FLUID TEMPERATURE °C {°F}	Max. working pressure (Normal temperature) MPa {psi}	Connection method			
			Flanged	Socket	Threaded	Spigot
U-PVC	0 ~ 50 { 30~120 }	1.6 { 230 }	○	○	○	○
C-PVC	0 ~ 80 { 30~175 }	1.6 { 230 }	○	○	○	—

Note::

- (1) The ball-type valves have dead spaces for structural reasons. Note that volatile liquids, such as hydrogen peroxide (H₂O₂) and sodium hypochlorite (NaClO), vaporize in those dead spaces, which may cause abnormal pressure increase in the valve. (When the internal pressure abnormally increases due to vaporization, the gas will be compressive fluid. If the valve breaks in this state, it will be very dangerous, causing explosion and scattering of fragments.)
- (2) The maximum working pressure is the value including the water hammer pressure. Be careful that the maximum working pressure is not exceeded during use.

* Concerning the allowable pressure for each temperature and material, see the technical documents at the next page of this sheet.

Certificate / Approval / Directive

PED

“For details of applicable products, please consult us.”

Maximum working pressure vs. Temperature

[JIS]

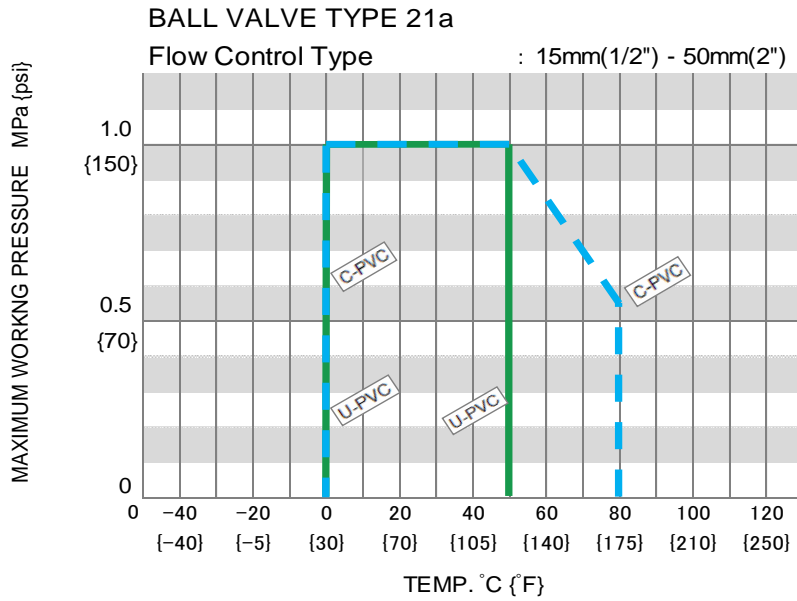

[DIN, ANSI]

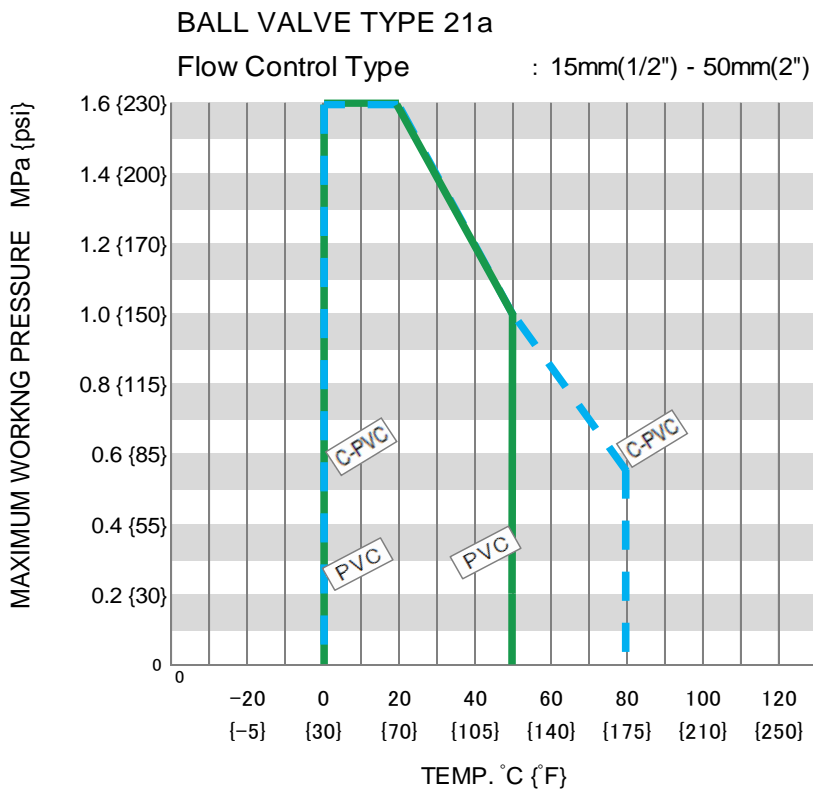

Product dimension

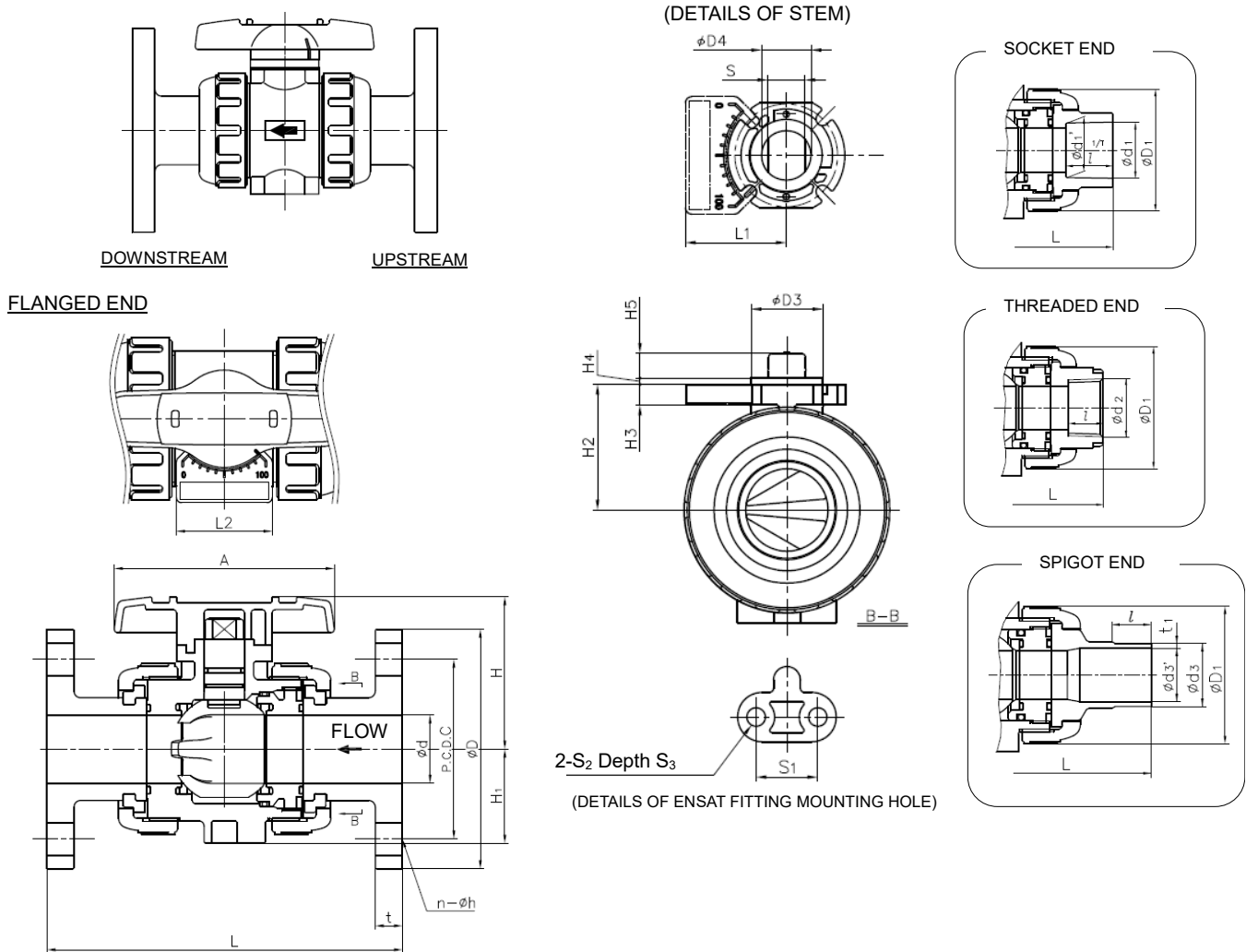

■ JIS, DIN (Unit: mm)

mm	inch	d	L1	L2	D ₁	D ₃	D ₄	H	H ₁	H ₂	H ₃	H ₄	H ₅	A	S	S ₁	S ₂	S ₃
15	1/2"	15	40	42	48	25	13.5	51.5	29	30.0	6	3	8	92	10.5	19	7.3	11
20	3/4	20	40	42	60	25	15	59.5	35	36.5	6	3	10	100	11	19	7.3	11
25	1	25	40	42	70	25	15	68.0	39	43.5	6	3	10	110	11	19	7.3	11
32	1 1/4	32	44	48	82	30	19	80.5	47	52.5	8	3	10	121	15	30	9.0	15
40	1 1/2	40	49	57	100	35	23	89.0	55	61.0	10	3	12	131	18	30	9.0	15
50	2	51	49	57	126	35	23	102.5	66	72.5	10	3	12	159	18	30	9.0	15

JIS (Unit: mm)

mm	inch	JIS														
		FLANGED END						SOCKET				THREADED				
		JIS 10K						d ₁	ℓ	1/T	L	d ₂	ℓ	L		
D	C	n	h	L	t	d ₁	ℓ								1/T	L
15	1/2"	95	70	4	15	143	12	22.11	20	1/34	109	Rc1/2	15	102		
20	3/4	100	75	4	15	172	14	26.13	24	1/34	128	Rc3/4	17	120		
25	1	125	90	4	19	187	14	32.16	27	1/34	145	Rc1	20	131		
32	1 1/4	135	100	4	19	190	16	38.19	30	1/34	162	Rc1 1/4	22	150		
40	1 1/2	140	105	4	19	212	16	48.21	37	1/37	189	Rc1 1/2	25	163		
50	2	155	120	4	19	234	16	60.25	42	1/37	220	Rc2	28	197		

DATASHEET

DIN (Unit: mm)

mm	inch	DIN															
		FLANGED						SOCKET			THREADED			SPIGOT			
		DIN PN10/PN16				L	t	d ₁	ℓ	L	d ₂	ℓ	L	d ₃	d ₃ '	ℓ	L
D	C	n	h														
15	1/2"	95	65	4	14	130	12	20	16	102	Rp1/2	15	102	20	15	18.5	124
20	3/4	105	75	4	14	150	14	25	19	119	Rp3/4	17	120	25	20	24	144
25	1	115	85	4	14	160	14	32	22	131	Rp1	20	131	32	25	24.5	154
32	1 1/4	140	100	4	18	180	16	40	26	150	Rp1 1/4	22	150	40	31	28	174
40	1 1/2	150	110	4	18	200	16	50	31	164	Rp1 1/2	25	163	50	40	34	194
50	2	165	125	4	18	230	16	63	38	197	Rp2	28	197	63	51	38	224

■ ANSI (Unit: inch)

inch	mm	d	L1	L2	D ₁	D ₃	D ₄	H	H ₁	H ₂	H ₃	H ₄	H ₅	A	S	S ₁	S ₂	S ₃
1/2	15	0.59	1.57	1.65	1.89	0.98	0.53	2.03	1.14	1.18	0.24	0.12	0.31	3.62	0.41	0.75	0.29	0.43
3/4	20	0.79	1.57	1.65	2.36	0.98	0.59	2.34	1.38	1.44	0.24	0.12	0.39	3.94	0.43	0.75	0.29	0.43
1	25	0.98	1.57	1.65	2.76	0.98	0.59	2.68	1.54	1.71	0.24	0.12	0.39	4.33	0.43	0.75	0.29	0.43
1 1/4	32	1.26	1.73	1.89	3.23	1.18	0.75	3.17	1.85	2.07	0.31	0.12	0.39	4.76	0.59	1.18	0.35	0.59
1 1/2	40	1.57	1.93	2.24	3.94	1.38	0.91	3.50	2.17	2.40	0.39	0.12	0.47	5.16	0.71	1.18	0.35	0.59
2	50	2.01	1.93	2.24	4.96	1.38	0.91	4.04	2.60	2.85	0.39	0.12	0.47	6.26	0.71	1.18	0.35	0.59

ANSI (Unit: inch)

inch	mm	ANSI													
		FLANGED						SOCKET				THREADED			
		ANSI CLASS 150				L	t	ASTM SCH80			L	d ₂	ℓ	L	
D	C	n	h	d ₁	d ₁ '			ℓ							
1/2	15	3.50	2.38	4	0.62	5.63	0.47	0.848	0.836	0.875	4.45	1/2 - 14 NPT	0.59	4.02	
3/4	20	3.88	2.75	4	0.62	6.77	0.55	1.058	1.046	1.000	5.08	3/4 - 14 NPT	0.67	4.72	
1	25	4.25	3.12	4	0.62	7.36	0.55	1.325	1.310	1.125	5.71	1-1 1/2 NPT	0.79	5.16	
1 1/4	32	4.62	3.50	4	0.62	7.48	0.63	1.670	1.655	1.250	6.46	1 1/4-11 1/2 NPT	0.87	5.91	
1 1/2	40	5.00	3.88	4	0.62	8.35	0.63	1.912	1.894	1.375	7.24	1 1/2-11 1/2 NPT	0.98	6.42	
2	50	6.00	4.75	4	0.75	9.21	0.63	2.387	2.369	1.500	8.23	2-11 1/2 NPT	1.10	7.76	

Note: The shape and appearance of assembly differ a little with nominal size compared to this drawing.

Parts list

FLANGED END

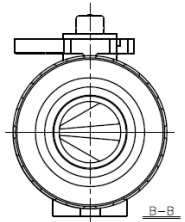
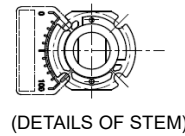
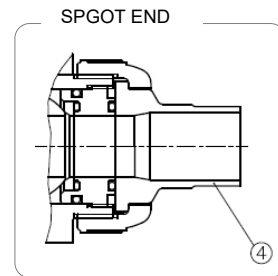
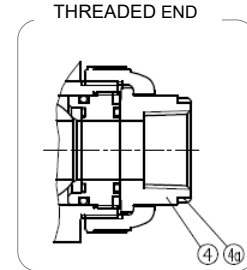
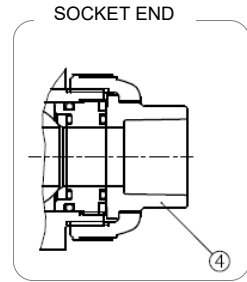
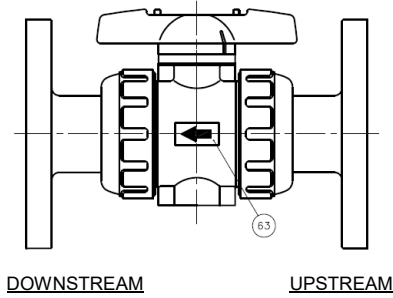
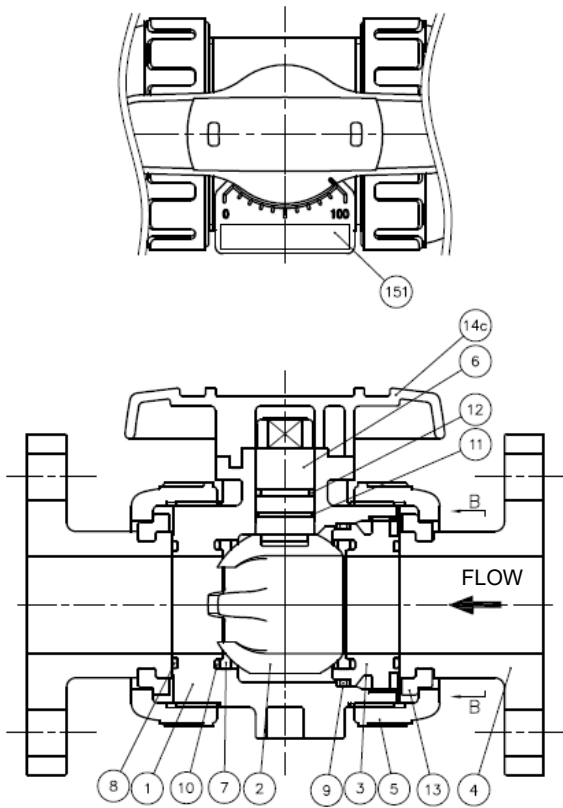

PART NO./NAME	QTY	MATERIAL	PART NO./NAME	QTY	MATERIAL	PART NO./NAME	QTY	MATERIAL
1 BODY	1	U-PVC, C-PVC	8 O-RING (A)	2	EPDM, FKM, Others ()	14c HANDLE	1	ABS
2 BALL For Flow Control Type.	1		9 O-RING (B)	1		151 INDICATOR	1	AES
3 CARRIER	2		10 O-RING (C)	2		63 FLOW INDICATIVE SEAL	1	—
4 END CONNECTOR	2		11 O-RING (D)	2		4a RING	2	STAINLESS STEEL Used for C-PVC BODY. Threaded End : 15mm(1/2") to 25mm(1")
5 UNION NUT	2		12 O-RING (E)	1				
6 STEM	1		13 STOP RING	2	PVDF Used for Flanged End			
7 SEAT	2		PTFE					

Cv value for each opening degree

BALL VALVE TYPE 21a

Flow Control Type

FULL-OPEN Cv VALUE

mm	15	20	25	32	40	50
inch	1/2	3/4	1	1 1/4	1 1/2	2
FULL-OPEN Cv VALUE	5.5	9.6	18	28	46	81

The values shown are reference values, not guaranteed values.

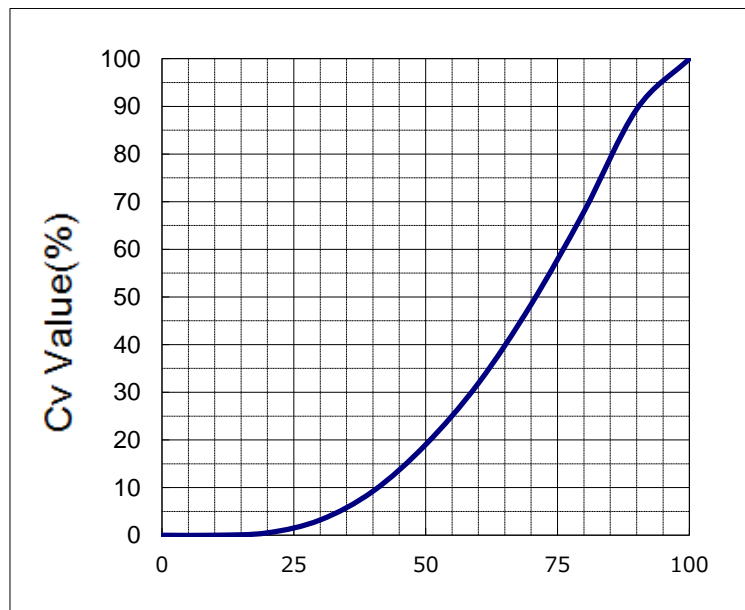

Operating torque

UNIT : N · m

mm	inch	Operation torque (O→S) N · m
15	1/2	2.0
20	3/4	2.5
25	1	3.2
32	1 1/4	5.6
40	1 1/2	8.0
50	2	10

ENSAT (METAL INSERT) MOUNTING PROCEDURE

BALL VALVE TYPE 21α (Flow Control Type) 15mm - 50mm



At the bottom of the valve body, a "holed bottom stand" is provided which can be easily secured to a rack or panel only by inserting an Ensat.

★ Install the metal insert (Ensats) in the procedure below.

<When using the special tool>

Attach the Ensats at the end of special tool with the splitting groove facing downward.

While ensuring that the center is aligned with the prepared hole from the front, back, right and left, screw the Ensats in to the predetermined depth.

After the Ensats is screwed in completely, hold the nut with a spanner while turning the upper portion of the tool in the reverse direction. The tool will be freely movable and come out.

<When using a bolt and nut>

Screw the Ensats in a double nut fashion. After the Ensats is screwed in, hold the bolt and loosen the nut. The bolt will be freely movable and can be removed.

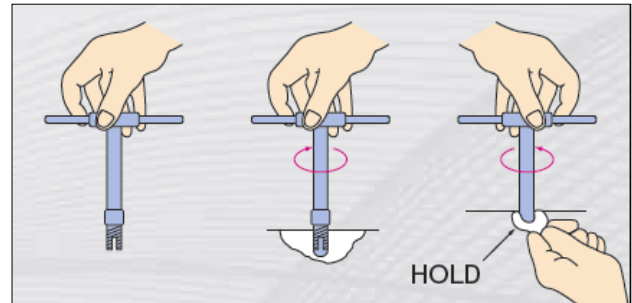
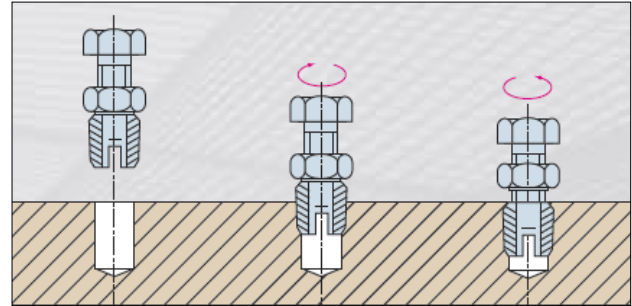

When the Ensats is manually screwed in, the center alignment between the Ensats and the prepared hole is particularly important. Check that the Ensats is inserted perpendicular to the prepared hole while screwing it in. If it is tilted, do not turn the tool backward, but just put the Ensats in its correct position. Note that, when nearly half of the Ensats is once inserted, its position can no longer be corrected.

NOTE For details of how to handle the Ensats mounting special tool, see to instruction manual provided by the Ensats manufacturer. (K.K.V.CORPORATION)

Product weight

BALL VALVE TYPE 21a

Flow Control Type

UNIT : kg

mm	inch	FLANGED		THREADED		SOCKET, SPIGOT	
		U-PVC	C-PVC	U-PVC	C-PVC	U-PVC	C-PVC
15	1/2	0.4	0.4	0.2	0.2	0.2	0.2
20	3/4	0.6	0.7	0.3	0.3	0.3	0.3
25	1	0.8	0.9	0.4	0.5	0.4	0.5
32	1 1/4	1.2	1.3	0.7	0.7	0.6	0.7
40	1 1/2	1.7	1.8	1.1	1.2	1.0	1.0
50	2	2.5	2.7	1.8	2.0	1.7	1.8

Spigot: U-PVC only.

Product model code list

ACTUATION		TYPE		OPERATING SYSTEM		BODY MATERIAL		SEAL MATERIAL		CONNECTION		STANDARD		SIZE	
V		2A		LC		*		*		*		***		***	
:		:		:		:		:		:		:		:	
V	MANUAL VALVE	2A	TYPE 21A	LC	FLOW CONTROL TYPE	U	U-PVC	E	EPDM	S	SOCKET	J	SOCKET	015	15mm
						C	C-PVC	V	FKM	N	THREADED	D	DIN	∅	
										P	SPIGOT	A	ANSI	050	50mm
										F	FLANGED	1	10K		

Installation, Operation and Maintenance Manual

"For details of Installation, Operation and Maintenance, please contact our nearest distribution agent or sales office.

https://www.asahi-yukizai.co.jp/en/product/detail/140131_000764.html